



UZ1085

LINEAR INTEGRATED CIRCUIT

3A ADJUSTABLE/FIXED LOW DROPOUT LINEAR REGULATOR

DESCRIPTION

The **UZ1085-xx** series are low dropout three-terminal regulators with 3A output current capability. These devices have been optimized for low voltage applications including VTT bus termination, where transient response and minimum input voltage are critical.

Current limit is trimmed to ensure specified output current and controlled short-circuit current. On-chip thermal limiting provides protection against any combination of overload and ambient temperature that would create excessive junction temperatures.

FEATURES

- *Fast transient response
- *Low dropout voltage at up to 3A
- *Load regulation:0.05% typical
- *Trimmed current limit
- *On-chip thermal limiting

ORDERING INFORMATION

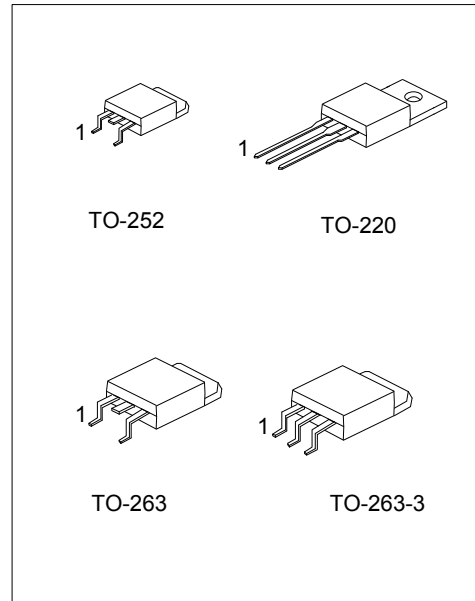

Lead-free: UZ1085L-xx
Halogen-free: UZ1085G-xx

Ordering Number			Package	Pin Assignment			Packing
Normal	Lead Free	Halogen Free		1	2	3	
UZ1085-xx-TA3-T	UZ1085L-xx-TA3-T	UZ1085G-xx-TA3-T	TO-220	A/G	O	I	Tube
UZ1085-xx-TN3-R	UZ1085L-xx-TN3-R	UZ1085G-xx-TN3-R	TO-252	A/G	O	I	Tape Reel
UZ1085-xx-TN3-T	UZ1085L-xx-TN3-T	UZ1085G-xx-TN3-T	TO-252	A/G	O	I	Tube
UZ1085-xx-TQ2-R	UZ1085L-xx-TQ2-R	UZ1085G-xx-TQ2-R	TO-263	A/G	O	I	Tape Reel
UZ1085-xx-TQ2-T	UZ1085L-xx-TQ2-T	UZ1085G-xx-TQ2-T	TO-263	A/G	O	I	Tube
UZ1085-xx-TQ3-R	UZ1085L-xx-TQ3-R	UZ1085G-xx-TQ3-R	TO-263-3	A/G	O	I	Tape Reel
UZ1085-xx-TQ3-T	UZ1085L-xx-TQ3-T	UZ1085G-xx-TQ3-T	TO-263-3	A/G	O	I	Tube

Note: 1. xx: Output Voltage, refer to Marking Information.

2. A: ADJ (for adjustable regulator), G: GND (for fixed regulator)

<p>UZ1085L-xx-TA3-T</p>	<p>(1) R: Tape Reel, T: Tube (2) TA3: TO-220, TN3: TO-252, TQ2: TO-263, TQ3: TO-263-3 (3) xx: refer to Marking Information (4) G: Halogen Free, L: Lead Free, Blank: Pb/Sn</p>
-------------------------	--

UZ1085

LINEAR INTEGRATED CIRCUIT

MARKING INFORMATION

PACKAGE	VOLTAGE CODE	MARKING
TO-220	15 :1.5V	
TO-252	18 :1.8V	
TO-263	25 :2.5V	
TO-263-3	33 :3.3V	
	50 :5.0V	
	AD :ADJ	

THERMAL DATA

PARAMETER		SYMBOL	RATINGS	UNIT
Junction-to-Ambient	TO-252	θ_{JA}	118	°C/W
	TO-220		62	
	TO-263		62	
Junction-to-Case	TO-252	θ_{JC}	12	°C/W
	TO-220		4	
	TO-263		4	

■ ABSOLUTE MAXIMUM RATINGS

PARAMETER	SYMBOL	RATINGS	UNIT
Input Voltage	V_{IN}	18	V
$(V_{IN} - V_{OUT}) * I_{OUT}$		See Figure 1	
Junction Temperature	T_J	+125	°C
Operating Temperature	T_{OPR}	-20 ~ +85	°C
Storage Temperature	T_{STG}	-40 ~ +150	°C

Note: Absolute maximum ratings are those values beyond which the device could be permanently damaged.

Absolute maximum ratings are stress ratings only and functional device operation is not implied.

■ ELECTRICAL CHARACTERISTICS (Ta=25°C, C_{OUT}=22 μF, unless otherwise specified.)

For UZ1085-ADJ(Adjustable)

PARAMETER	SYMBOL	TEST CONDITIONS	MIN.	TYP.	MAX.	UNIT
Reference Voltage	V_{REF}	$1.5V \leq (V_{IN} - V_{OUT}) \leq 8.25V$ $10mA \leq I_{OUT} \leq 3A$	1.225	1.25	1.275	V
Line Regulation	ΔV_{OUT}	$(V_{OUT} + 1.5V) \leq V_{IN} \leq 12V,$ $I_{OUT} = 10mA$		0.005	0.2	%
Load Regulation	ΔV_{OUT}	$(V_{IN} - V_{OUT}) = 3V, 10mA \leq I_{OUT} \leq 3A$		0.05	0.5	%
Dropout Voltage	V_D	$\Delta V_{REF} \% = 1\%, I_{OUT} = 3A$		1.30	1.40	V
Current Limit	I_{LIMIT}	$(V_{IN} - V_{OUT}) = 2V$	3.1	4		A
Adjust Pin Current	I_{adj}			35	120	μA
Adjust Pin Current Change	ΔI_{adj}	$1.5V \leq (V_{IN} - V_{OUT}) \leq 12V,$ $10mA \leq I_{OUT} \leq 3A$		0.2	5	μA
Minimum Load Current	$I_{O(MIN)}$	$1.5V \leq (V_{IN} - V_{OUT}) \leq 12V$			10	mA
Quiescent Current	I_Q	$V_{IN} = 12V$		4	13	mA
Ripple Rejection	RR	$f = 120Hz, \text{Tantalum}, (V_{IN} - V_{OUT}) = 3V$ $I_{OUT} = 3A$	60	72		dB
Thermal Regulation		Ta=25°C, 30ms pulse		0.004	0.02	%/W
Temperature Stability	ΔV_{OUT}			0.5		%
Long-Term Stability	ΔV_{OUT}	Ta=125°C, 1000hr		0.03	1.0	%
Output Noise(% of V _{OUT})	eN	Ta=25°C, 10Hz $\leq f \leq$ 10kHz		0.003		%
Thermal Shutdown				150		°C

For UZ1085-xx(Fixed Voltage)

PARAMETER	SYMBOL	TEST CONDITIONS	MIN.	TYP.	MAX.	UNIT
Output Voltage	UZ1085-15	$3.0V \leq V_{IN} \leq 8.5V, 10mA \leq I_{OUT} \leq 3A$	1.470	1.5	1.530	V
	UZ1085-18	$3.3V \leq V_{IN} \leq 8.8V, 10mA \leq I_{OUT} \leq 3A$	1.764	1.8	1.830	
	UZ1085-25	$4.0V \leq V_{IN} \leq 9.5V, 10mA \leq I_{OUT} \leq 3A$	2.450	2.5	2.550	
	UZ1085-33	$4.8V \leq V_{IN} \leq 10.3V, 10mA \leq I_{OUT} \leq 3A$	3.234	3.3	3.366	
	UZ1085-50	$6.5V \leq V_{IN} \leq 12V, 10mA \leq I_{OUT} \leq 3A$	4.900	5.0	5.100	
Line Regulation	ΔV_{OUT}	$(V_{OUT} + 1.5V) \leq V_{IN} \leq 12V, I_{OUT} = 10mA$		0.005	0.2	%
Load Regulation	ΔV_{OUT}	$(V_{IN} - V_{OUT}) = 3V, 10mA \leq I_{OUT} \leq 3A$		0.05	0.5	%
Dropout Voltage	V_D	$\Delta V_{REF} \% = 1\%, I_{OUT} = 3A$		1.30	1.40	V
Current Limit	I_{LIMIT}	$(V_{IN} - V_{OUT}) = 2V$	3.1	4		A
Minimum Load Current	$I_{O(MIN)}$	$1.5V \leq (V_{IN} - V_{OUT}) \leq 12V$			10	mA
Quiescent Current	I_Q	$V_{IN} = 12V$		4	13	mA
Ripple Rejection	RR	$f = 120Hz, \text{Tantalum},$ $(V_{IN} - V_{OUT}) = 3V, I_{OUT} = 3A$	60	72		dB
Thermal Regulation		Ta=25°C, 30ms pulse		0.004	0.02	%/W
Temperature Stability	ΔV_{OUT}	Ta=125°C, 1000hr		0.5		%
Long-Term Stability	ΔV_{OUT}			0.03	1.0	%
Output Noise(% of V _{OUT})	eN	Ta=25°C, 10Hz $\leq f \leq$ 10kHz		0.003		%
Thermal shutdown				150		°C

■ TYPICAL APPLICATION CIRCUIT

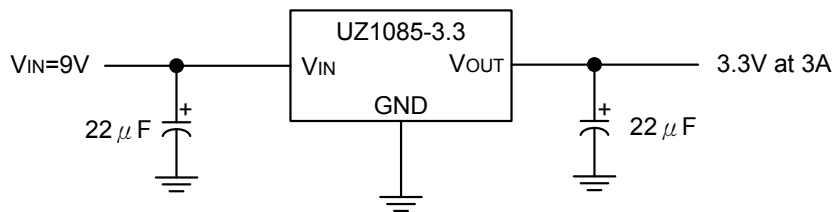
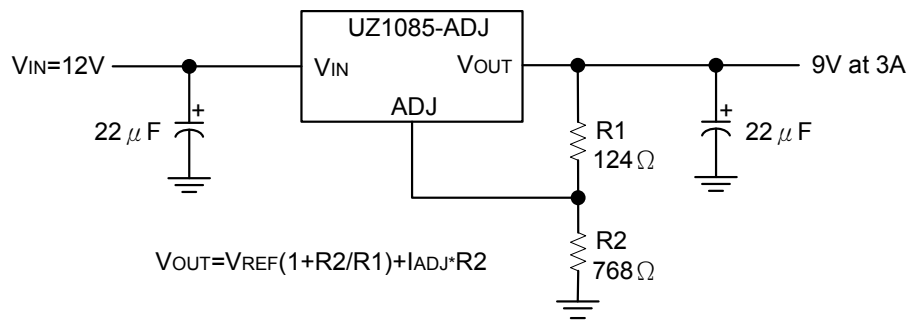

TYPICAL CHARACTERISTICS

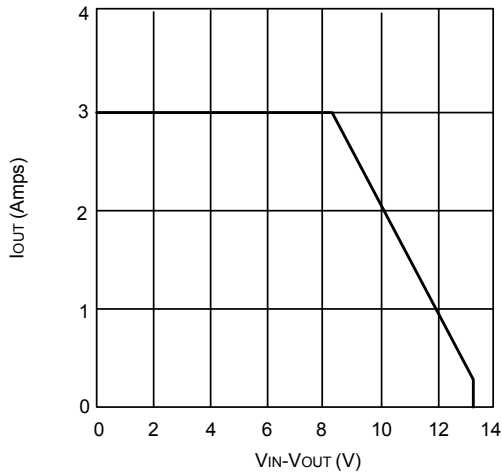

Figure 1. Absolute Maximum Safe Operating Area

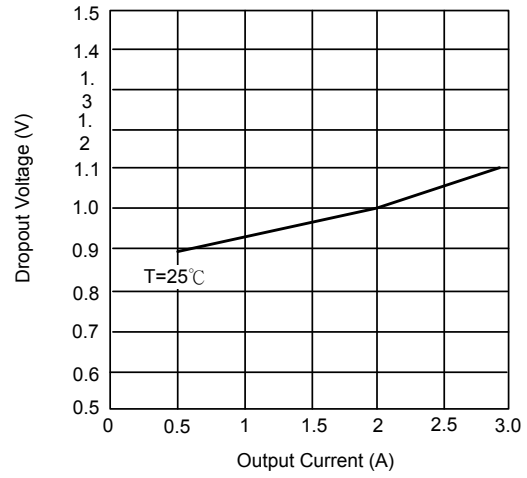

Figure 2. Dropout Voltage vs. Output Current

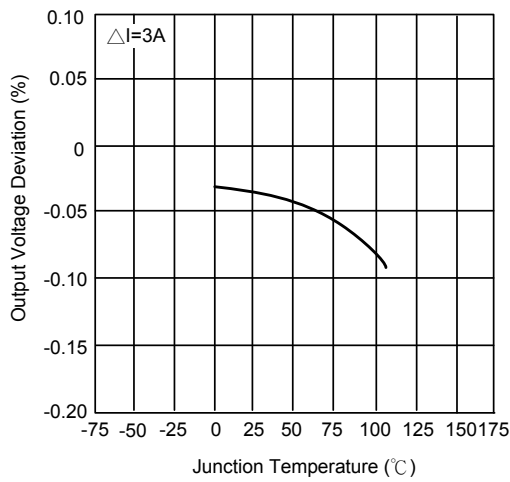

Figure 3. Load Regulation vs. Temperature

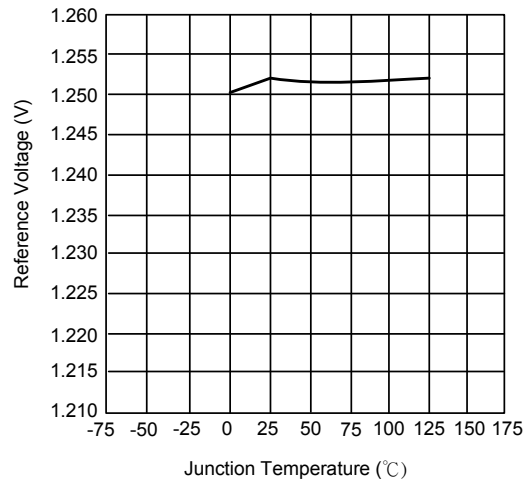

Figure 4. Reference Voltage vs. Temperature

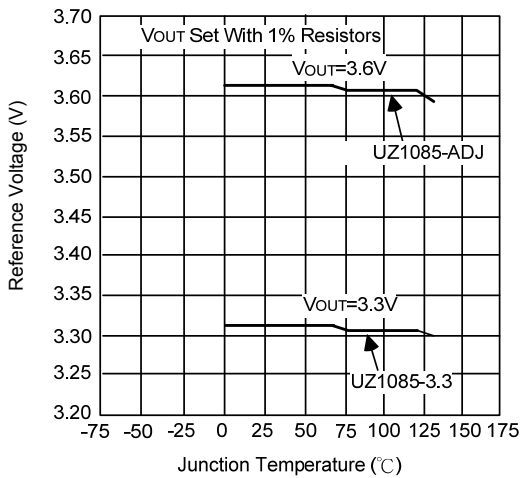

Figure 5. Output Voltage vs. Temperature

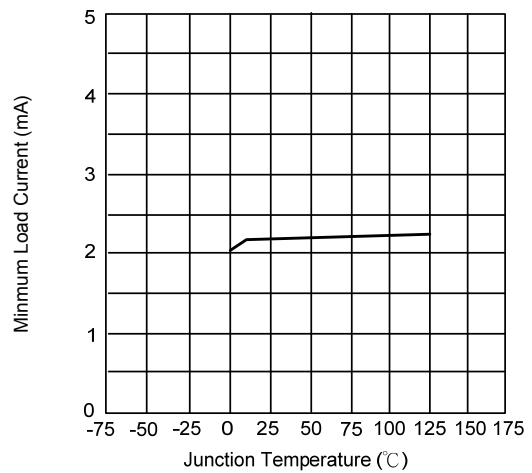

Figure 6. Minimum Load Current vs. Temperature

■ TYPICAL CHARACTERISTICS(Cont.)

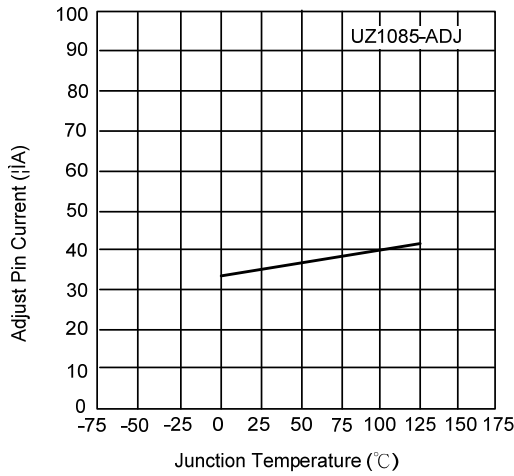

Figure 7. Adjust Pin Current vs. Temperature

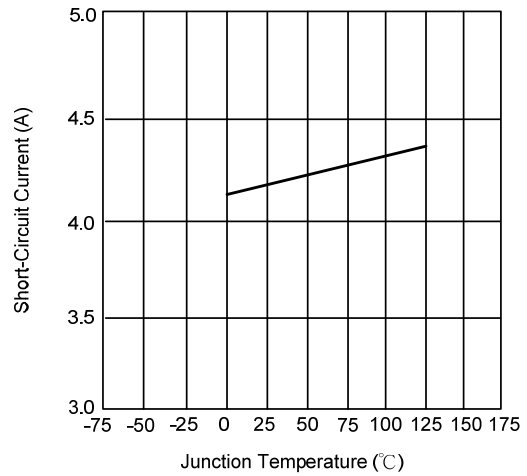

Figure 8. Short-Circuit Current vs. Temperature

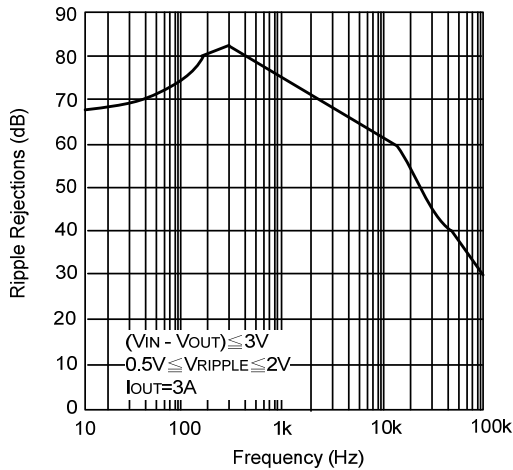

Figure 9. Ripple Rejection vs. Frequency

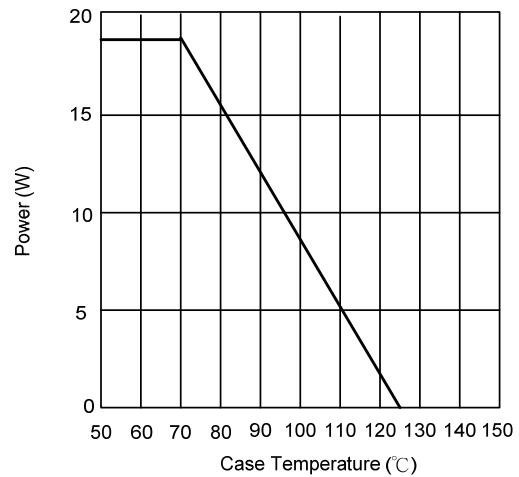

Figure 10. Maximum Power Dissipation

UTC assumes no responsibility for equipment failures that result from using products at values that exceed, even momentarily, rated values (such as maximum ratings, operating condition ranges, or other parameters) listed in products specifications of any and all UTC products described or contained herein. UTC products are not designed for use in life support appliances, devices or systems where malfunction of these products can be reasonably expected to result in personal injury. Reproduction in whole or in part is prohibited without the prior written consent of the copyright owner. The information presented in this document does not form part of any quotation or contract, is believed to be accurate and reliable and may be changed without notice.