



## UH277

## LINEAR INTEGRATED CIRCUIT

### COMPLEMENTARY OUTPUTS HALL EFFECT LATCH IC

#### DESCRIPTION

The UTC **UH277** is a Latch-Type Hall Effect sensor with built-in complementary output drivers. It's designed with internal temperature compensation circuit and built-in protection diode prevent reverse power fault. The application is aimed for brush-less DC Fan

The **UH277** Outputs operate as the Hysteresis Characteristics. The Outputs alternately ON and OFF when either the magnetic flux density larger than threshold  $B_{OP}$  or the magnetic flux density lower than  $B_{RP}$ .

#### FEATURES

- \* Widen Power Supply range from 3V ~ 20V.
- \* On-chip Hall sensor with excellent hysteresis.
- \* Open Collector outputs had the sinking capability up to 300mA.
- \* Output Clamping Diodes reduce the peak output voltages during switching.
- \* Build-in reverse protection diode.

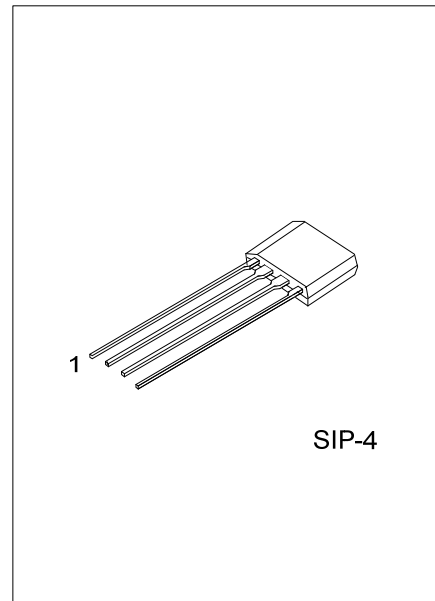

Lead-free: UH277L  
Halogen-free: UH277G

#### ORDERING INFORMATION

Ordering Number			Package	Packing
Normal	Lead Free Plating	Halogen Free		
UH277-G04-K	UH277L-G04-K	UH277G-G04-K	SIP-4	Bulk

<p>UH277L-G04-K</p> <p>(1) Packing Type (2) Package Type (3) Lead Plating</p>	<p>(1) B: Bulk (2) G04: SIP-4 (3) G: Halogen Free, L: Lead Free, Blank: Pb/Sn</p>
---	---

#### PIN DESCRIPTION

PIN NO.	PIN NAME	P/I/O	DESCRIPTION
1	$V_{CC}$	P	Positive Power Supply
2	DO	O	Output Pin
3	DOB	O	Output Pin
4	$V_{SS}$	P	Ground

## ■ BLOCK DIAGRAM

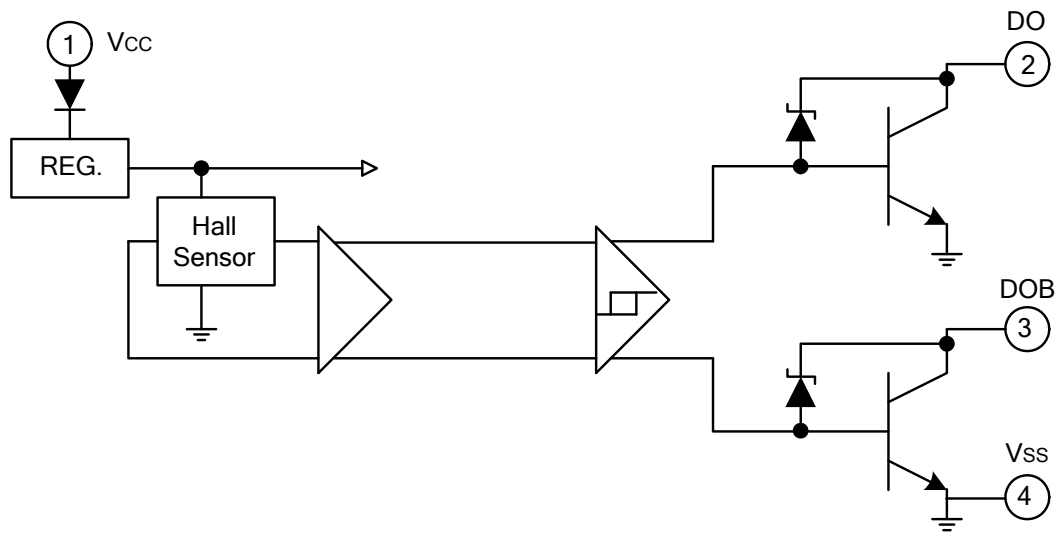

## ■ SENSOR LOCATIONS

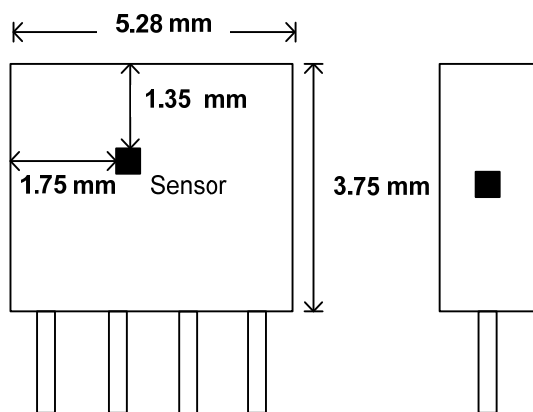

■ ABSOLUTE MAXIMUM RATINGS (Ta=25°C)

PARAMETER		SYMBOL	RATINGS	UNIT
Supply Voltage		V <sub>CC</sub>	20	V
Reverse V <sub>CC</sub> Polarity Voltage		V <sub>RCC</sub>	-25	V
Output OFF Voltage		V <sub>CE</sub>	32	V
Magnetic flux density		B	Unlimited	
Output ON Current	Continuous	I <sub>c</sub>	0.3	A
	Hold		0.4	
	Peak (Start Up)		0.7	
Power Dissipation		P <sub>D</sub>	500	mW
Junction Temperature		T <sub>J</sub>	+150	°C
Operating Temperature		T <sub>OPR</sub>	-20 ~ +85	°C
Storage Temperature		T <sub>STG</sub>	-65 ~ +150	°C

Note 1: Output Zener protection voltage

■ ELECTRICAL CHARACTERISTICS (Ta =25°C, unless otherwise specified)

PARAMETER	SYMBOL	TEST CONDITIONS	MIN	TYP	MAX	UNIT
Low Supply Voltage	V <sub>CE</sub>	V <sub>CC</sub> =3.5V, I <sub>L</sub> =100mA			0.6	V
Supply Voltage	V <sub>CC</sub>		3		20	V
Output Saturation Voltage	V <sub>CE(SAT)</sub>	V <sub>CC</sub> =14V, I <sub>L</sub> =300mA		0.3	0.6	V
Output Leakage Current	I <sub>CEX</sub>	V <sub>CE</sub> =14V, V <sub>CC</sub> =14V		<0.1	10	μA
Supply Current	I <sub>CC</sub>	V <sub>CC</sub> =20V, Output Open		15	25	mA
Output Rise Time	t <sub>R</sub>	V <sub>CC</sub> =14V, R <sub>L</sub> =820Ω, C <sub>L</sub> =20pF		0.3	3	μS
Output Falling Time	t <sub>F</sub>	V <sub>CC</sub> =14V, R <sub>L</sub> =820Ω, C <sub>L</sub> =20pF		0.04	1	μS
Switch Time Differential	Δt	V <sub>CC</sub> =14V, R <sub>L</sub> =820Ω, C <sub>L</sub> =20pF		0.3	3	μS

■ MAGNETIC CHARACTERISTICS

A grade

PARAMETR	SYMBOL	MIN	TYP	MAX	UNIT
Operate Point	B <sub>OP</sub>	5		50	G
Release Point	B <sub>RP</sub>	-50		-5	G
Hysteresis	B <sub>HYS</sub>	20		100	G

B grade

PARAMETR	SYMBOL	MIN	TYP	MAX	UNIT
Operate Point	B <sub>OP</sub>	5		70	G
Release Point	B <sub>RP</sub>	-70		-5	G
Hysteresis	B <sub>HYS</sub>	20		140	G

C grade

PARAMETR	SYMBOL	MIN	TYP	MAX	UNIT
Operate Point	B <sub>OP</sub>			100	G
Release Point	B <sub>RP</sub>	-100			G
Hysteresis	B <sub>HYS</sub>	20		200	G

■ CHYSTERESIS CHARACTERISTICS

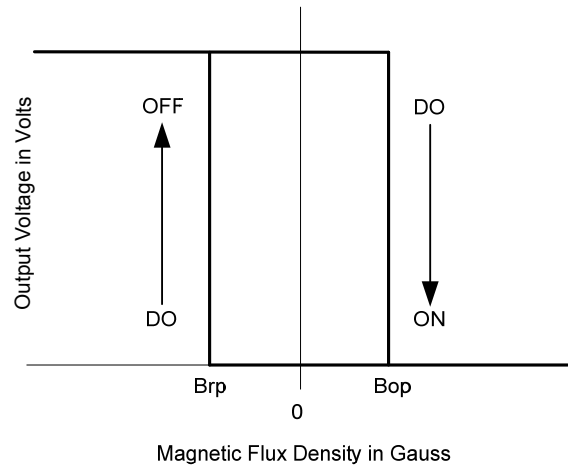
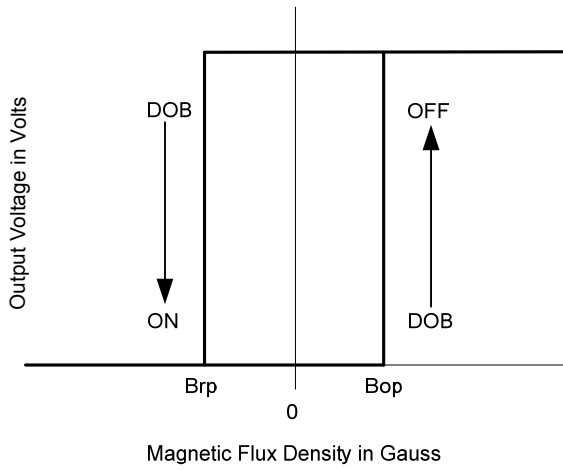

## ■ TYPICAL APPLICATION CIRCUIT

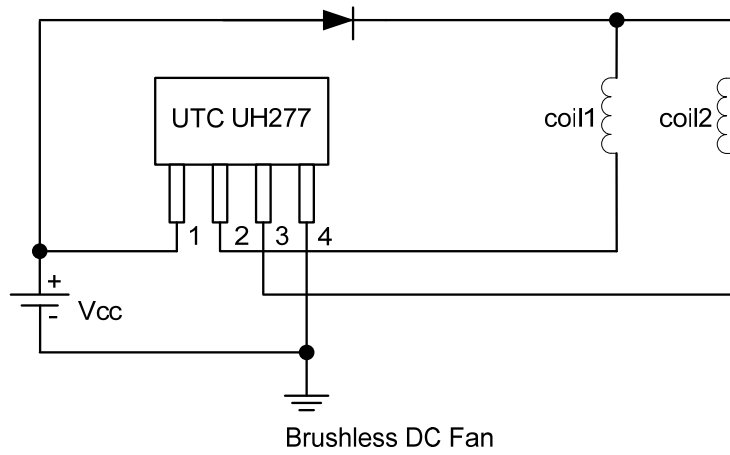

## ■ TEST CIRCUIT

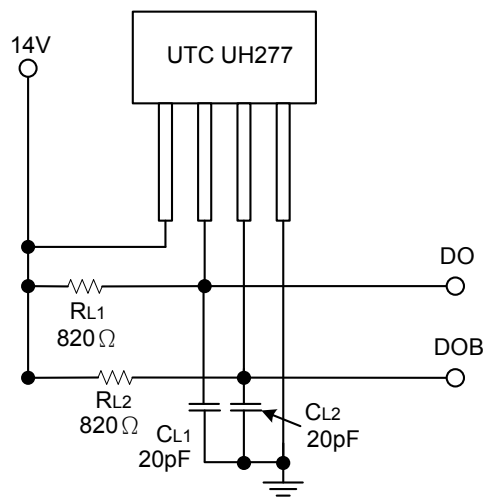

## ■ PERFORMANCE CHARACTERISTICS

Ta(°C)	25	50	60	70	80	85	90	95	100	105	110	115	120
P <sub>D</sub> (mW)	550	525	515	505	485	475	465	455	445	425	405	385	365

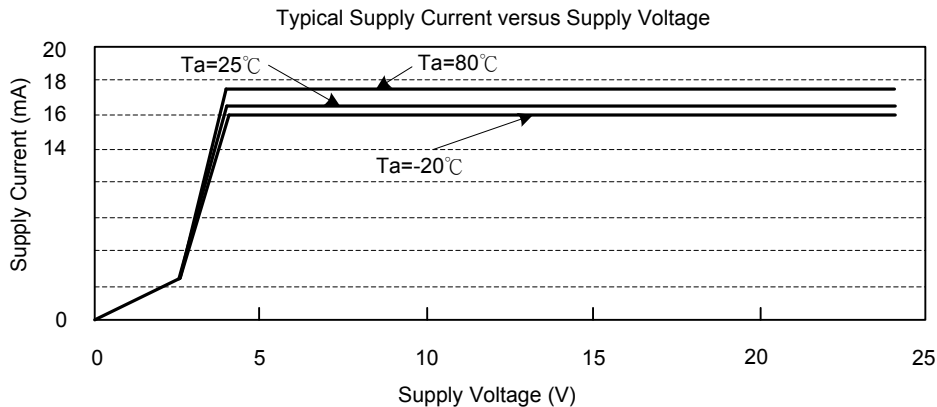
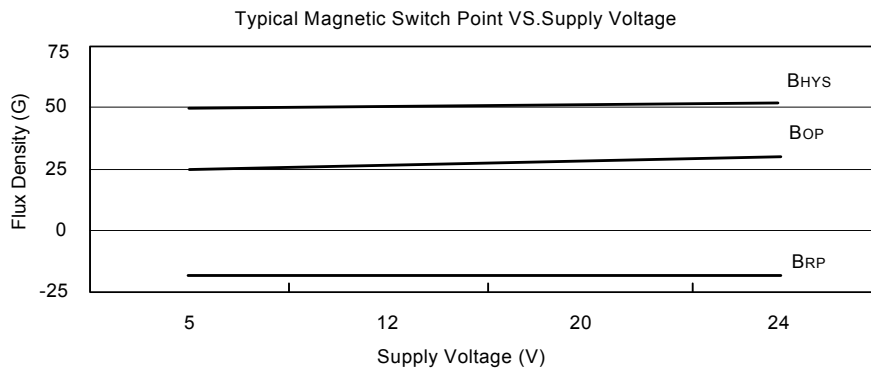
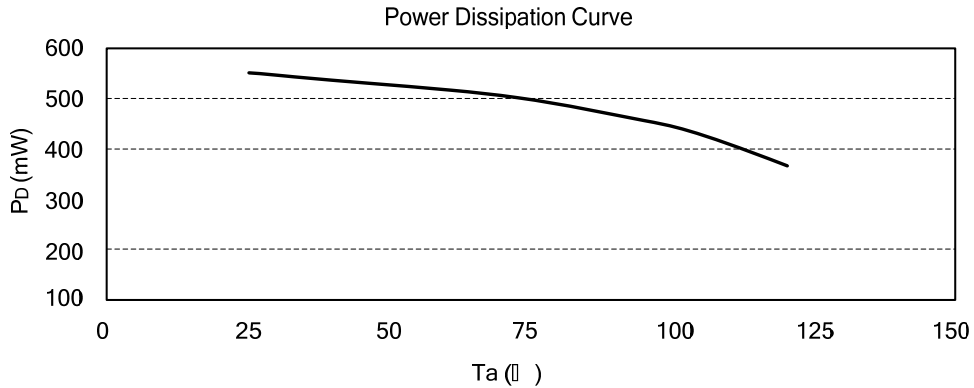

UTC assumes no responsibility for equipment failures that result from using products at values that exceed, even momentarily, rated values (such as maximum ratings, operating condition ranges, or other parameters) listed in products specifications of any and all UTC products described or contained herein. UTC products are not designed for use in life support appliances, devices or systems where malfunction of these products can be reasonably expected to result in personal injury. Reproduction in whole or in part is prohibited without the prior written consent of the copyright owner. The information presented in this document does not form part of any quotation or contract, is believed to be accurate and reliable and may be changed without notice.