



TDA7266

LINEAR INTEGRATED CIRCUIT

7+7W DUAL BRIDGE AMPLIFIER

DESCRIPTION

The UTC **TDA7266** is a 7+7W dual bridge amplifier specially designed for TV and Portable Radio applications.

FEATURES

- * Wide supply voltage range (3 ~ 18V)
- * Minimum external components
- * No SWR capacitor
- * No bootstrap
- * No boucherot cells
- * Internally fixed gain
- * STAND-BY & MUTE functions
- * Short circuit protection
- * Thermal overload protection

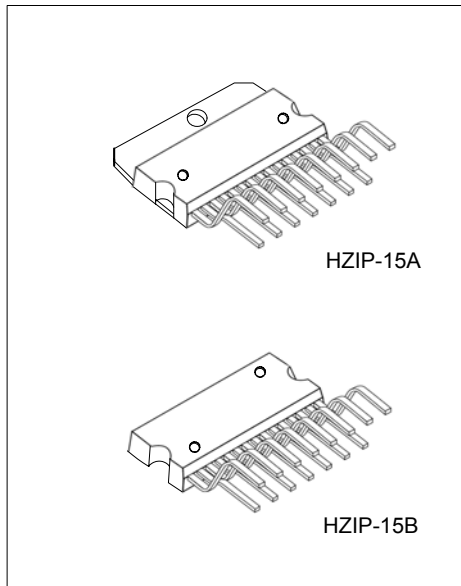

*Pb-free plating product number: TDA7266L

ORDERING INFORMATION

Ordering Number		Package	Packing
Normal	Lead Free Plating		
TDA7266-J15-A-T	TDA7266L-J15-A-T	HZIP-15A	Tube
TDA7266-J15-B-T	TDA7266L-J15-B-T	HZIP-15B	Tube

<p>TDA7266L-J15-A-T</p> <p>(1)Packing Type</p> <p>(2)Package Type</p> <p>(3)Lead Plating</p>	<p>(1) T: Tube</p> <p>(2) J15-A: HZIP-15A, J15-B: HZIP-15B</p> <p>(3) L: Lead Free Plating, Blank: Pb/Sn</p>
--	--

■ PIN CONFIGURATION

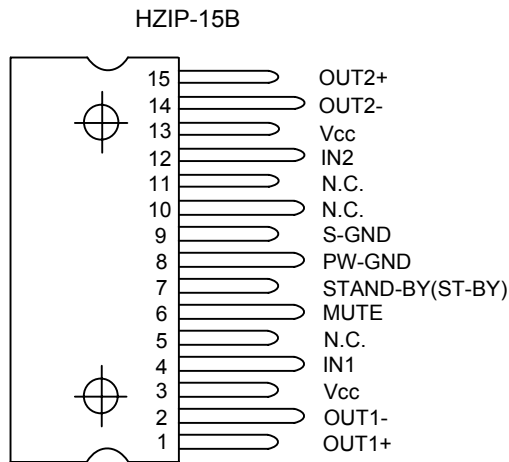
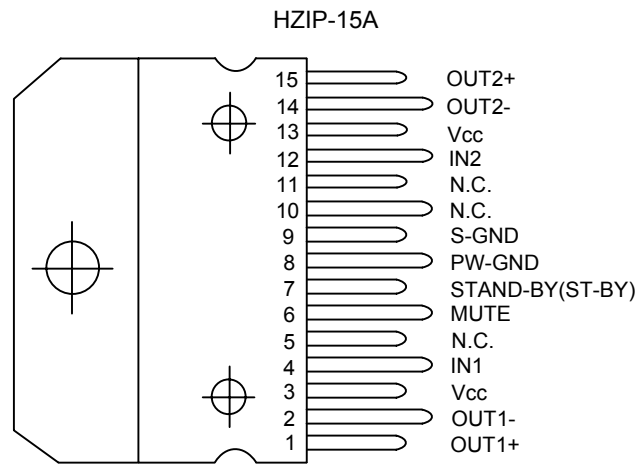

■ BLOCK DIAGRAM

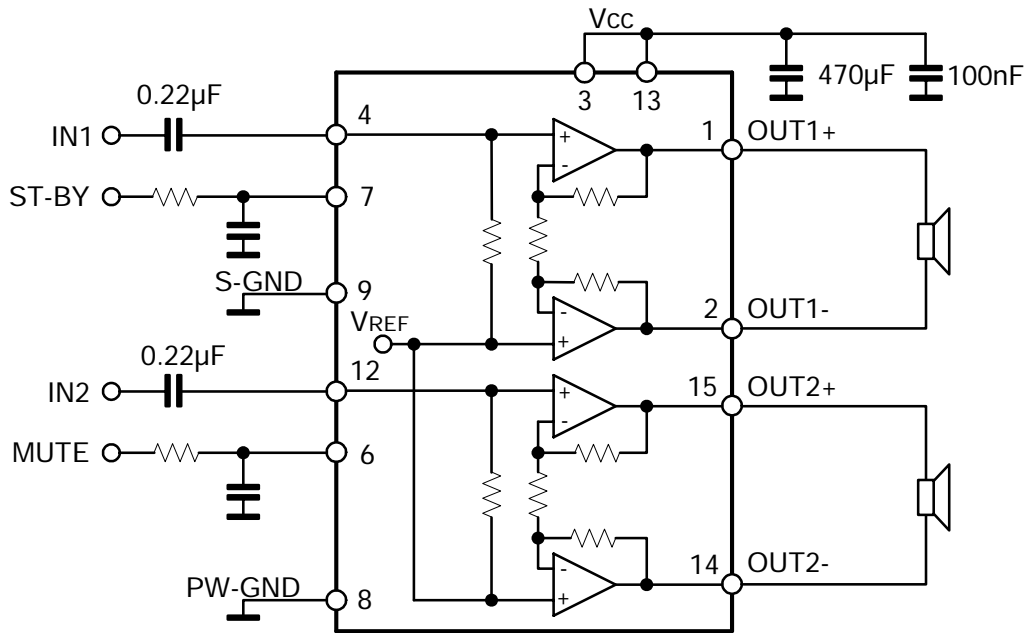

■ ABSOLUTE MAXIMUM RATINGS

PARAMETER	SYMBOL	RATINGS	UNIT
Supply Voltage	V_{CC}	20	V
Output Peak Current (internally limited)	I_{OUT}	2	A
Power Dissipation ($T_C = 70^\circ$)	P_D	33	W
Junction Temperature	T_J	+125	
Operating Temperature	T_{OPR}	0 ~ +70	
Storage Temperature	T_{STG}	-40 ~ +150	

Note: Absolute maximum ratings are those values beyond which the device could be permanently damaged.
 Absolute maximum ratings are stress ratings only and functional device operation is not implied.

■ THERMAL DATA

PARAMETER	SYMBOL	RATINGS	UNIT
Thermal Resistance Junction to Case	θ_{JC}	1.4	/W

■ ELECTRICAL CHARACTERISTICS ($V_{CC}=11V$, $R_L=8\Omega$, $f=1kHz$, $T_a=25^\circ$, unless otherwise specified)

PARAMETER	SYMBOL	TEST CONDITIONS	MIN	TYP	MAX	UNIT
Supply Range	V_{CC}		3	11	18	V
Output Offset Voltage	$V_{O(OFF)}$				120	mV
Total Output Noise Voltage	eN	A curve, $f=20Hz \sim 20kHz$		150		μV
Total Quiescent Current	I_Q			48	65	mA
Input Resistance	R_{IN}		25	30		k Ω
Output Power	P_{OUT}	THD=10%	6.3	7		W
Total Harmonic Distortion	THD	$P_{OUT}=1W$		0.05	0.2	%
		$P_{OUT}=0.1 \sim 2W$, $f=100Hz \sim 15kHz$			1	%
Crosstalk	C_T		46	60		dB
Closed Loop Voltage Gain	Gv		25	26	27	dB
Voltage Gain Matching	Gv				0.5	dB
Supply Voltage Rejection	SVR	$f=100Hz$, $V_R=0.5V$	40	56		dB
Thermal Threshold	Tt			150		

MUTE FUNCTION

Mute Threshold	VM_{THD}	for $V_{CC} > 6.4V$, $V_{OUT} = -30dB$	2.3	2.9	4.1	V
		for $V_{CC} < 6.4V$, $V_{OUT} = -30dB$	$V_{CC}/2-1.0$	$V_{CC}/2-0.75$	$V_{CC}/2-0.5$	V
Mute Attenuation	$AMUTE$		60	80		dB

STAND BY FUNCTION

STAND-BY Threshold	VT_{ST-BY}		0.8	1.3	1.8	V
STAND-BY Current $V_6=GND$	I_{ST-BY}				100	μA

■ APPLICATION SUGGESTION

For Microprocessor Application

In order to avoid annoying "Pop-Noise" during Turn-On/Off transients, it is necessary to guarantee the right ST-BY and MUTE signals sequence. It is quite simple to obtain this function using a microprocessor (Fig 1 and Fig 2).

At first ST-BY signal (from mP) goes high and the voltage across the ST-BY terminal (Pin 7) starts to increase exponentially. The external RC network is intended to turn-on slowly the biasing circuits of the amplifier, this to avoid "POP" and "CLICK" on the outputs.

When this voltage reaches the ST-BY threshold level, the amplifier is switched-on and the external capacitors in series to the input terminals (C3, C5) start to charge.

It's necessary to maintain the mute signal low until the capacitors are fully charged, this to avoid that the device goes in play mode causing a loud "Pop Noise" on the speakers.

A delay of 100 ~ 200ms between ST-BY and MUTE signals is suitable for a proper operation.

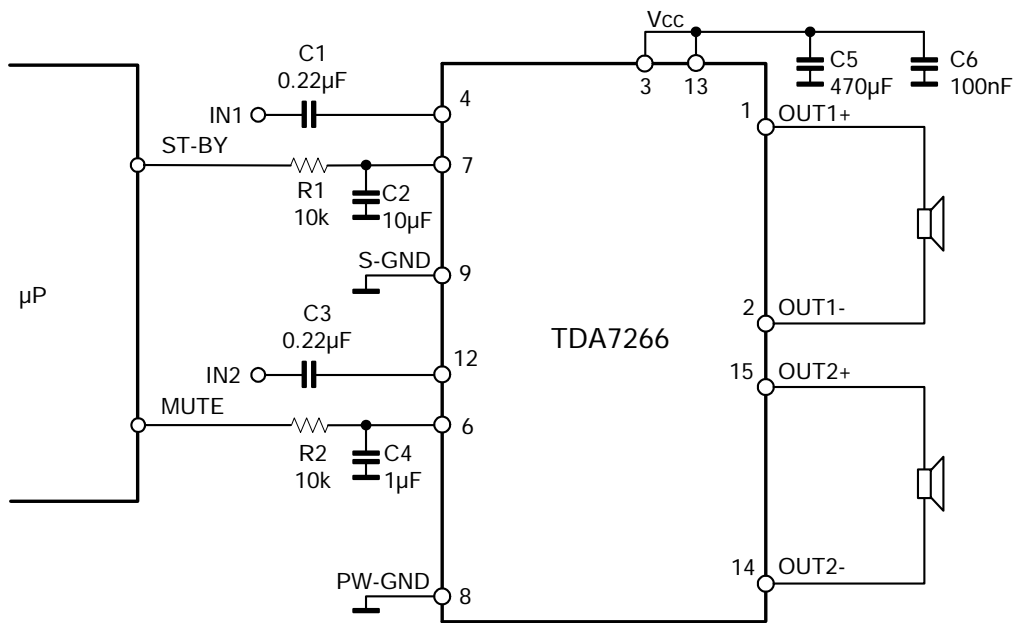

Fig. 1 Microprocessor Application

■ APPLICATION SUGGESTION(Cont.)

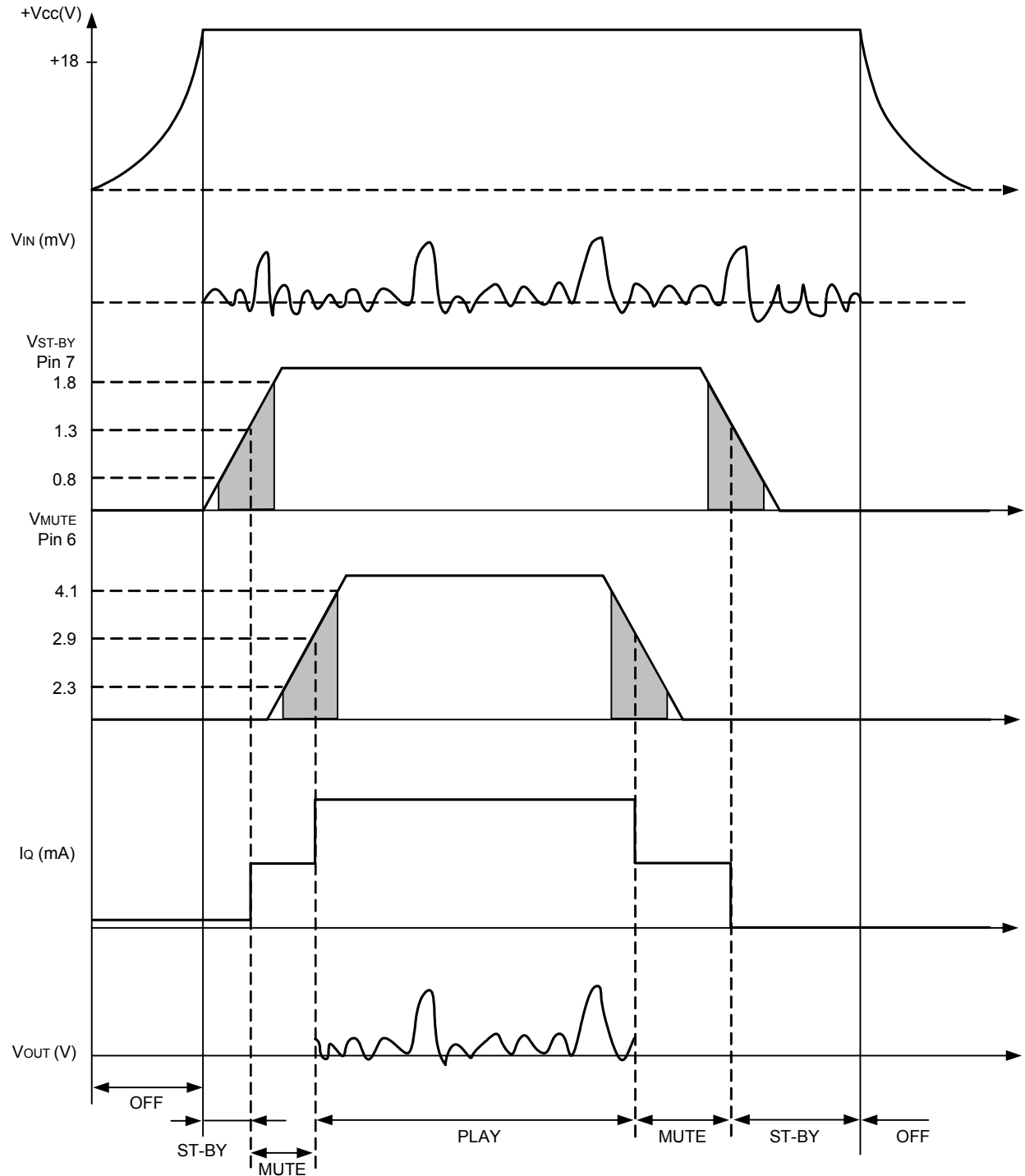

Fig 2 Microprocessor Driving Signals

■ APPLICATION SUGGESTION(Cont.)

For Low Cost Application

In low cost applications where the mP is not present, the suggested circuit is shown in Fig 3.

The ST-BY and mute terminals are tied together and they are connected to the supply line via an external voltage divider.

The device is switched-on/off from the supply line and the external capacitor C4 is intended to delay the ST-BY and MUTE threshold exceeding, avoiding "Popping" problems.

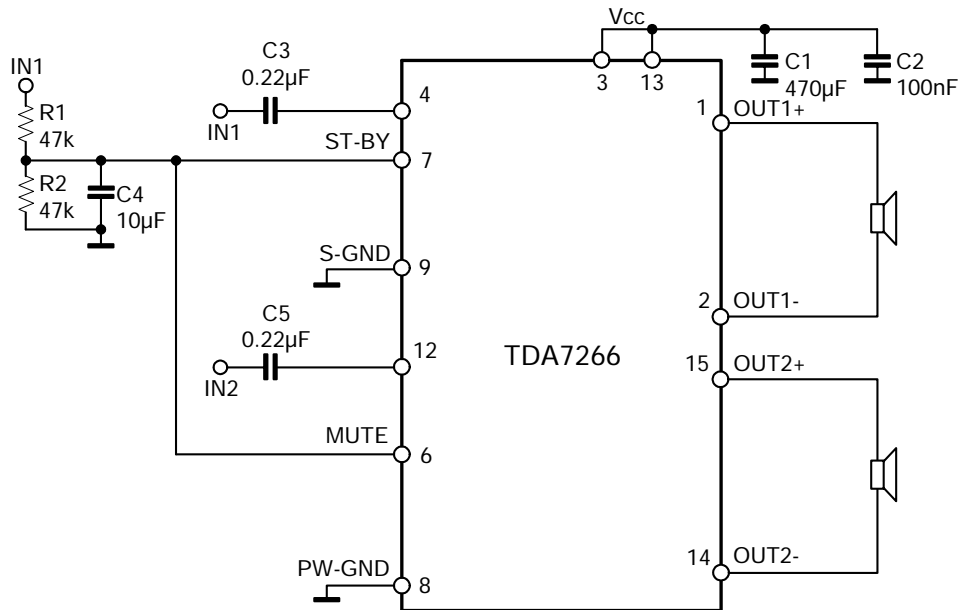
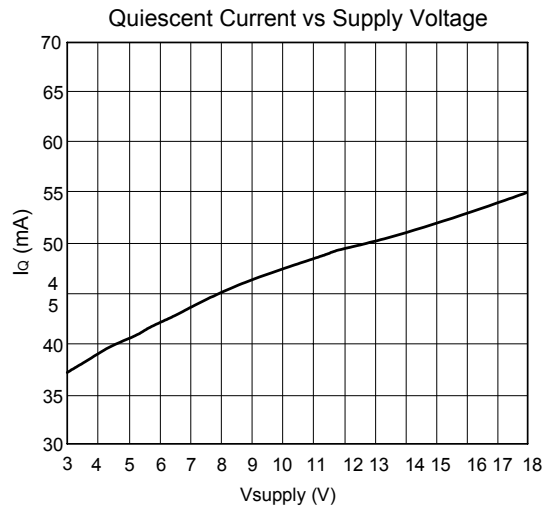
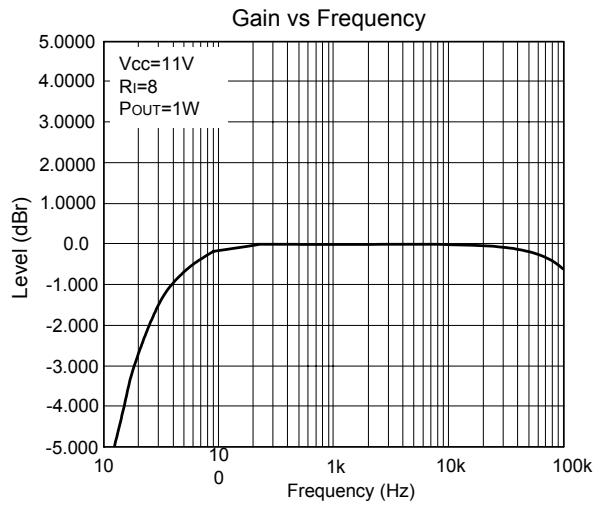

Fig 3 Stand Alone Low Cost Application

■ TYPICAL CHARACTERISTICS



UTC assumes no responsibility for equipment failures that result from using products at values that exceed, even momentarily, rated values (such as maximum ratings, operating condition ranges, or other parameters) listed in products specifications of any and all UTC products described or contained herein. UTC products are not designed for use in life support appliances, devices or systems where malfunction of these products can be reasonably expected to result in personal injury. Reproduction in whole or in part is prohibited without the prior written consent of the copyright owner. The information presented in this document does not form part of any quotation or contract, is believed to be accurate and reliable and may be changed without notice.