



## TA7368P

### LINEAR INTEGRATED CIRCUIT

## 0.6W AUDIO POWER AMPLIFIER

### DESCRIPTION

The UTC **TA7368P** is suitable for the audio power amplifier of portable cassette tape recorder and radio.

### FEATURES

- \* Very few external components(only three capacitors)
- \* Low quiescent current
- \* High voltage gain:  $G_v=40\text{dB}$

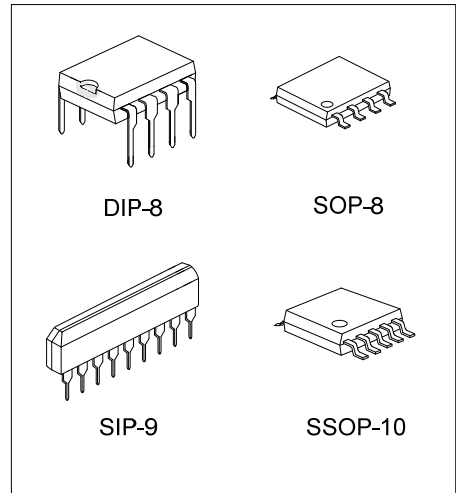

Lead-free: TA7368PL  
 Halogen-free: TA7368PG

### ORDERING INFORMATION

| Ordering Number |                |                | Package | Packing   |
|-----------------|----------------|----------------|---------|-----------|
| Normal          | Lead Free      | Halogen Free   |         |           |
| TA7368P-D08-T   | TA7368PL-D08-T | TA7368PG-D08-T | DIP-8   | Tube      |
| TA7368P-G09-T   | TA7368PL-G09-T | TA7368PG-G09-T | SIP-9   | Tube      |
| TA7368P-R10-R   | TA7368PL-R10-R | TA7368PG-R10-R | SSOP-10 | Tape Reel |
| TA7368P-R10-T   | TA7368PL-R10-T | TA7368PG-R10-T | SSOP-10 | Tube      |
| TA7368P-S08-R   | TA7368PL-S08-R | TA7368PG-S08-R | SOP-8   | Tape Reel |

|  |   |
|--|---|
| <p>TA7368PL-D08-T</p> <p>(1)Packing Type<br/>       (2)Package Type<br/>       (3)Lead Plating</p> | <p>(1) R: Tape Reel, T: Tube<br/>       (2) D08: DIP-8, G09: SIP-9, R10: SSOP-10, S08: SOP-8<br/>       (3) G: Halogen Free, L: Lead Free, Blank: Pb/Sn</p> |
|--|---|

### ■ PIN CONFIGURATIONS

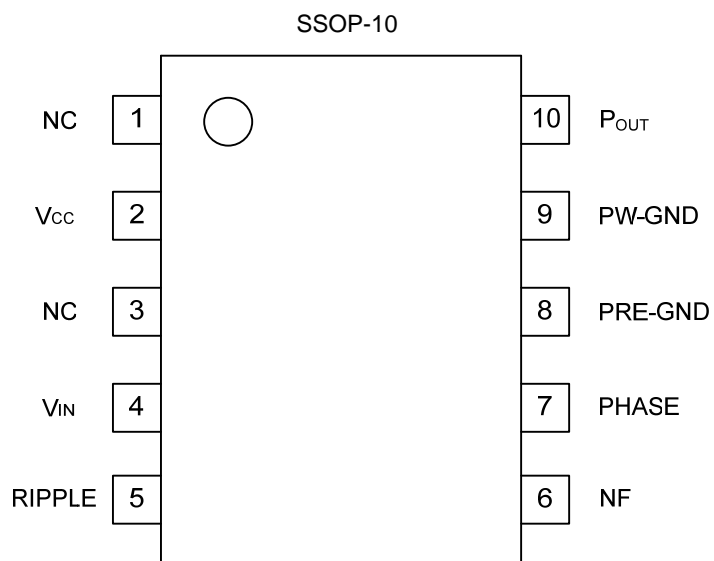
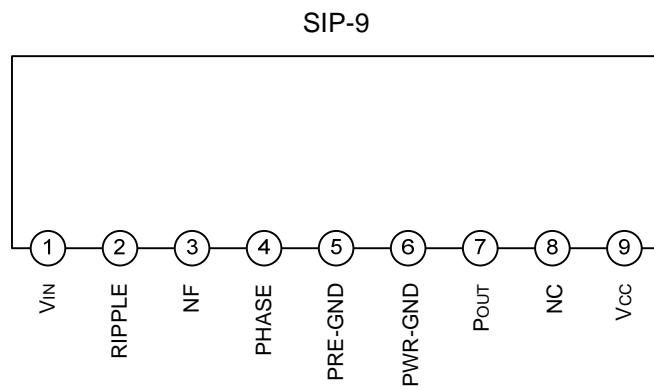
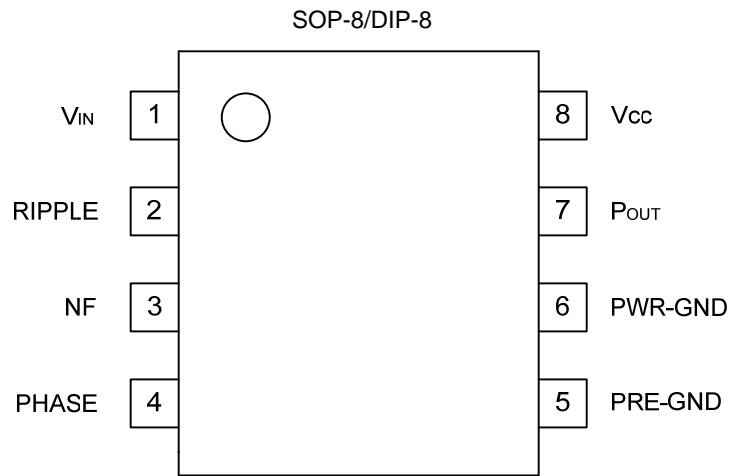

# TA7368P

## LINEAR INTEGRATED CIRCUIT

### ■ BLOCK DIAGRAMS

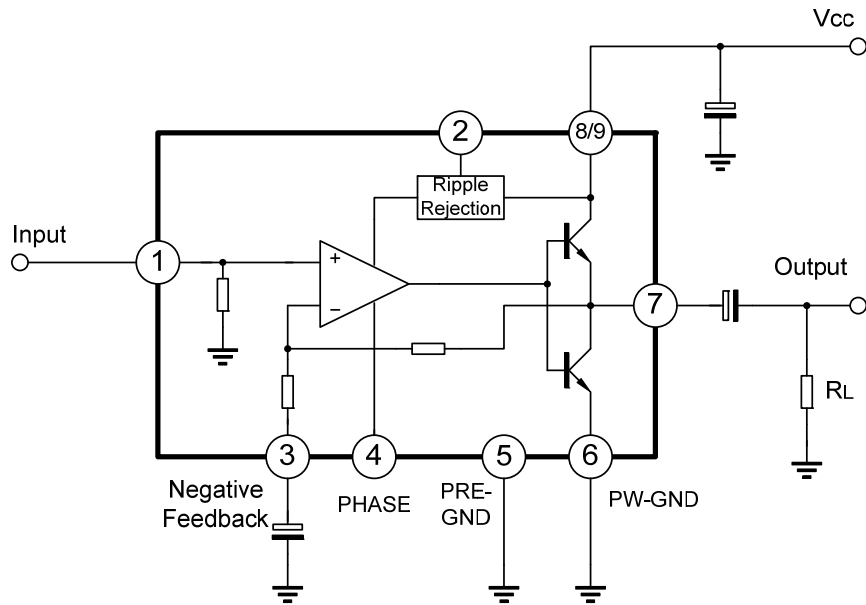

Note: Pin connection  
DIP-8/SOP-8: PIN⑧:V<sub>CC</sub>  
SIP-9: PIN⑧: NC, PIN⑨:V<sub>CC</sub>

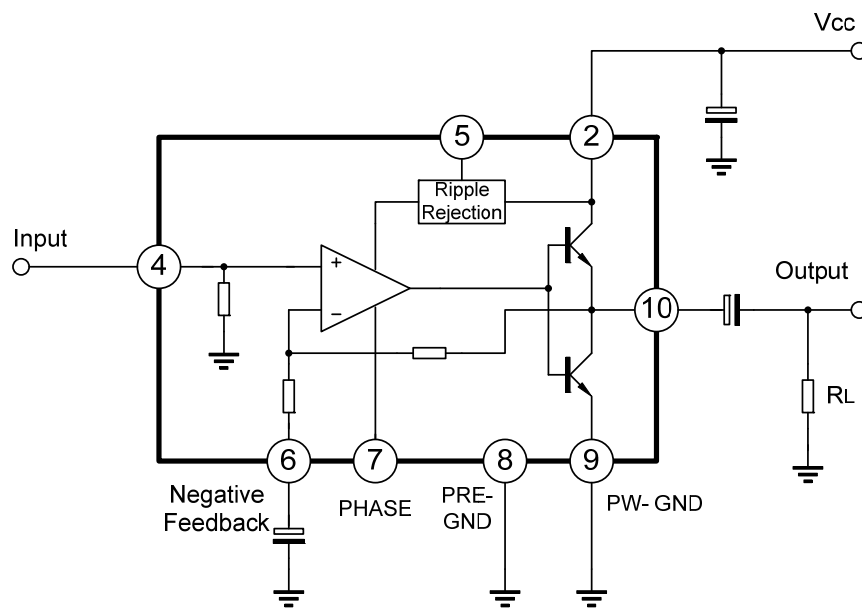

Note: Pin connection for SSOP-10 package only.

### ■ ABSOLUTE MAXIMUM RATINGS (Ta=25°C)

| PARAMETER             |               | SYMBOL           | RATINGS    | UNIT |
|-----------------------|---------------|------------------|------------|------|
| Supply Voltage        |               | V <sub>CC</sub>  | 14         | V    |
| Power Dissipation     | DIP-8         | P <sub>D</sub>   | 900        | mW   |
|                       | SIP-9         |                  | 950        |      |
|                       | SOP-8/SSOP-10 |                  | 400        |      |
| Operating Temperature |               | T <sub>OPR</sub> | -20 ~ +75  | °C   |
| Storage Temperature   |               | T <sub>STG</sub> | -55 ~ +150 | °C   |

Note: 1. Absolute maximum ratings are those values beyond which the device could be permanently damaged.

Absolute maximum ratings are stress ratings only and functional device operation is not implied.

2. Derated Ta>25°C, in the proportion of 7.2mW/°C

### ■ ELECTRONIC CHARACTERISTICS

(Ta=25°C, V<sub>CC</sub>=6V, f=1kHz, R<sub>G</sub>=600Ω, R<sub>L</sub>=4Ω, unless otherwise specified)

| PARAMETER                 | SYMBOL           | TEST CONDITIONS  | MIN | TYP | MAX | UNIT  |
|---------------------------|------------------|--|-----|-----|-----|-------|
| Quiescent Circuit Current | I <sub>CCQ</sub> | V <sub>CC</sub> =3V, V <sub>IN</sub> =0                |     | 5.5 |     | mA    |
|                           |                  | V <sub>CC</sub> =9V, V <sub>IN</sub> =0                |     | 6.6 | 18  |       |
|                           |                  | V <sub>CC</sub> =14V, V <sub>IN</sub> =0               |     | 7.5 | 21  |       |
| Voltage Gain              | G <sub>V</sub>   | V <sub>IN</sub> =0.5mVrms                              | 37  | 40  | 43  | dB    |
| Output Power              | P <sub>OUT</sub> | V <sub>CC</sub> =3V, R <sub>L</sub> =4Ω, THD=10%       |     | 120 |     | mW    |
|                           |                  | V <sub>CC</sub> =6V, R <sub>L</sub> =4Ω, THD=10%       | 500 | 720 |     |       |
|                           |                  | V <sub>CC</sub> =9V, R <sub>L</sub> =8Ω, THD=10%       | 800 | 610 |     |       |
| Total Harmonic Distortion | THD              | P <sub>OUT</sub> =100mW                                |     | 0.3 | 1   | %     |
| Output Noise Voltage      | eN               | R <sub>G</sub> =10kΩ, BPF=20Hz~20kHz                   |     | 0.2 | 0.5 | mVrms |
| Ripple Rejection          | RR               | f <sub>R</sub> =100Hz, V <sub>R</sub> =0.3Vrms, Crip=0 |     | 25  |     | dB    |
| Input Resistance          | R <sub>IN</sub>  |  |     | 27  |     | kΩ    |

### ■ TERMINAL DC VOLTAGE

Typical terminal voltage at no signal with test circuit (V<sub>CC</sub>=6V, Ta=25°C)

| Pin No.       | 1 | 2   | 3    | 4    | 5 | 6 | 7    | 8  | 9 |
|---------------|---|-----|------|------|---|---|------|----|---|
| DC Voltage(V) | 0 | 2.4 | 0.62 | 0.64 | 0 | 0 | 2.61 | NC | 6 |

## ■ PRECAUTION FOR APPLICATION

### 1. Input stage (Figure 1)

The input stage of power amplifier is comprised of a PNP differential pair (Q2 and Q3) preceded by a PNP emitter follower (Q1) which allows DC referencing of the source signal to GND. This eliminates the need for an input coupling capacitor. However, in case the brush noise of volume becomes a problem, provide serially a coupling capacitor to the input side.

### 2. Adjustment of the voltage gain (Figure 2)

The voltage gain is fixed at  $G_v=40\text{dB}$  by the resistors (R4 and R5) in IC. Its reduction is possible through adding  $R_f$  as shown in Figure 2. In this case, the voltage gain is obtained by the following equation:  $G_v=20\log(R_5+R_4+R_f)/(R_4+R_f)$ . It is recommended to use this IC with the voltage gain of  $G_v=28\text{dB}$  or over.

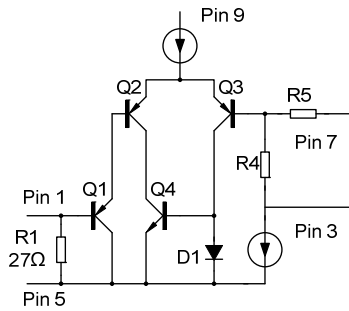

Figure 1

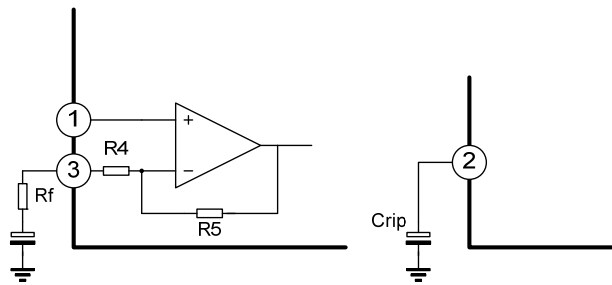

Figure 2

Figure 3

### 3. Ripple Rejection (Figure 3)

Adding Crip, to the ripple terminal 2 as shown in Figure 3, the ripple rejection ratio is improved from  $-25\text{dB}$  to  $-45\text{dB}$ .

### 4. Power dissipation

Casre should be taken to use IC below maximum power dissipation because it may be over maximum rating depending on operating condition.

$P_d=900\text{mW}$  ( $T_a=25^\circ\text{C}$ )

### 5. Phase-compensation

Small temperature coefficient and excellent frequency characteristics is needed by capacitor below:

\*Oscillation preventing capacitor for power amplifier output

\*Bypass capacitor for ripple filter

\*Capacitor between  $V_{cc}$  and GND

# TA7368P

## LINEAR INTEGRATED CIRCUIT

### ■ TEST CIRCUITS

For SOP-8/DIP-8/SIP-9 Package

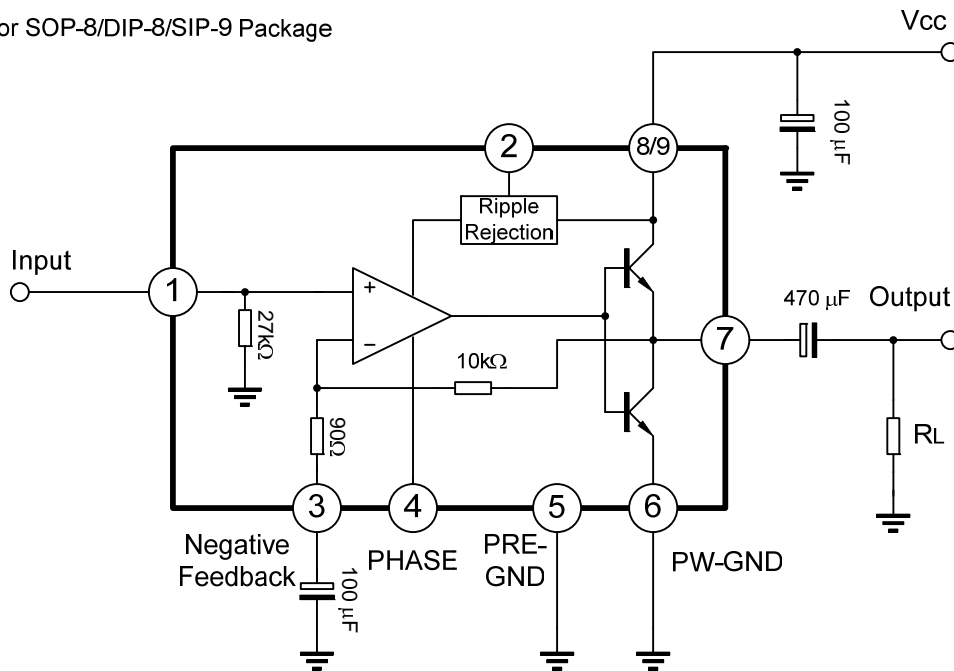

For SSOP-10 Package

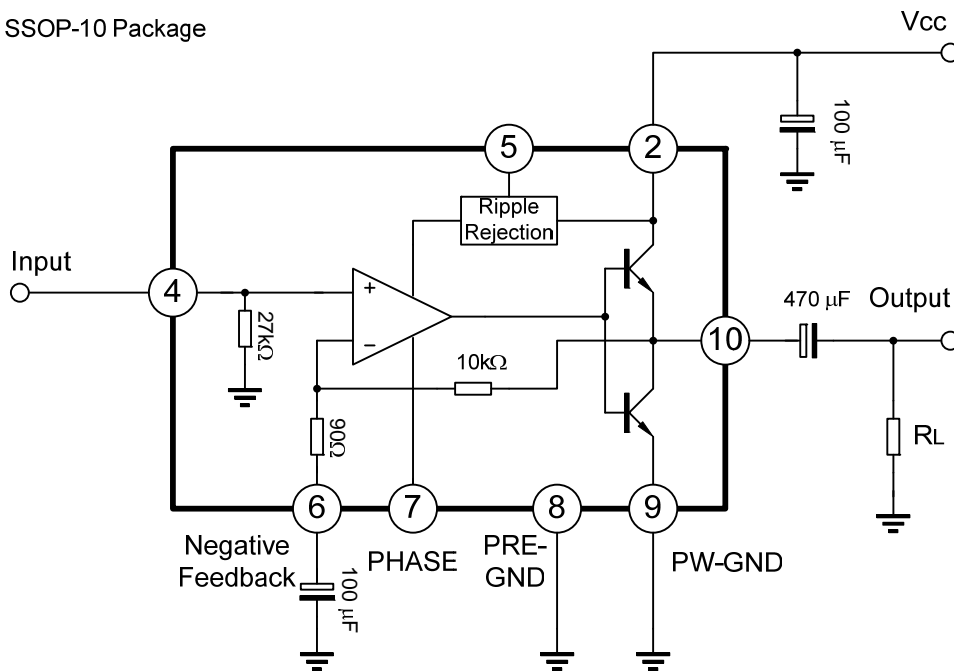

UTC assumes no responsibility for equipment failures that result from using products at values that exceed, even momentarily, rated values (such as maximum ratings, operating condition ranges, or other parameters) listed in products specifications of any and all UTC products described or contained herein. UTC products are not designed for use in life support appliances, devices or systems where malfunction of these products can be reasonably expected to result in personal injury. Reproduction in whole or in part is prohibited without the prior written consent of the copyright owner. The information presented in this document does not form part of any quotation or contract, is believed to be accurate and reliable and may be changed without notice.